

● 2.5L  
 ▲ 3.9L

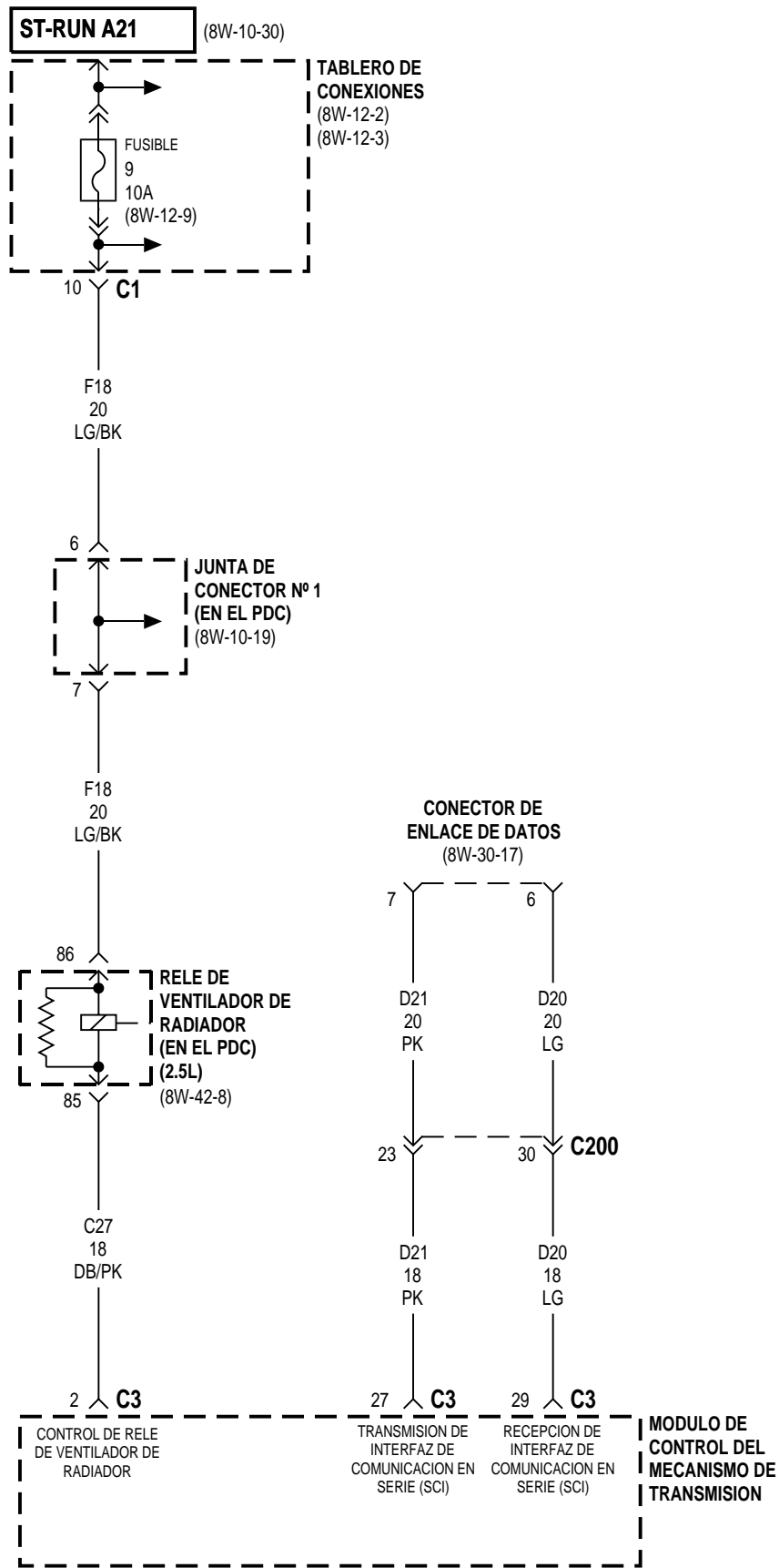

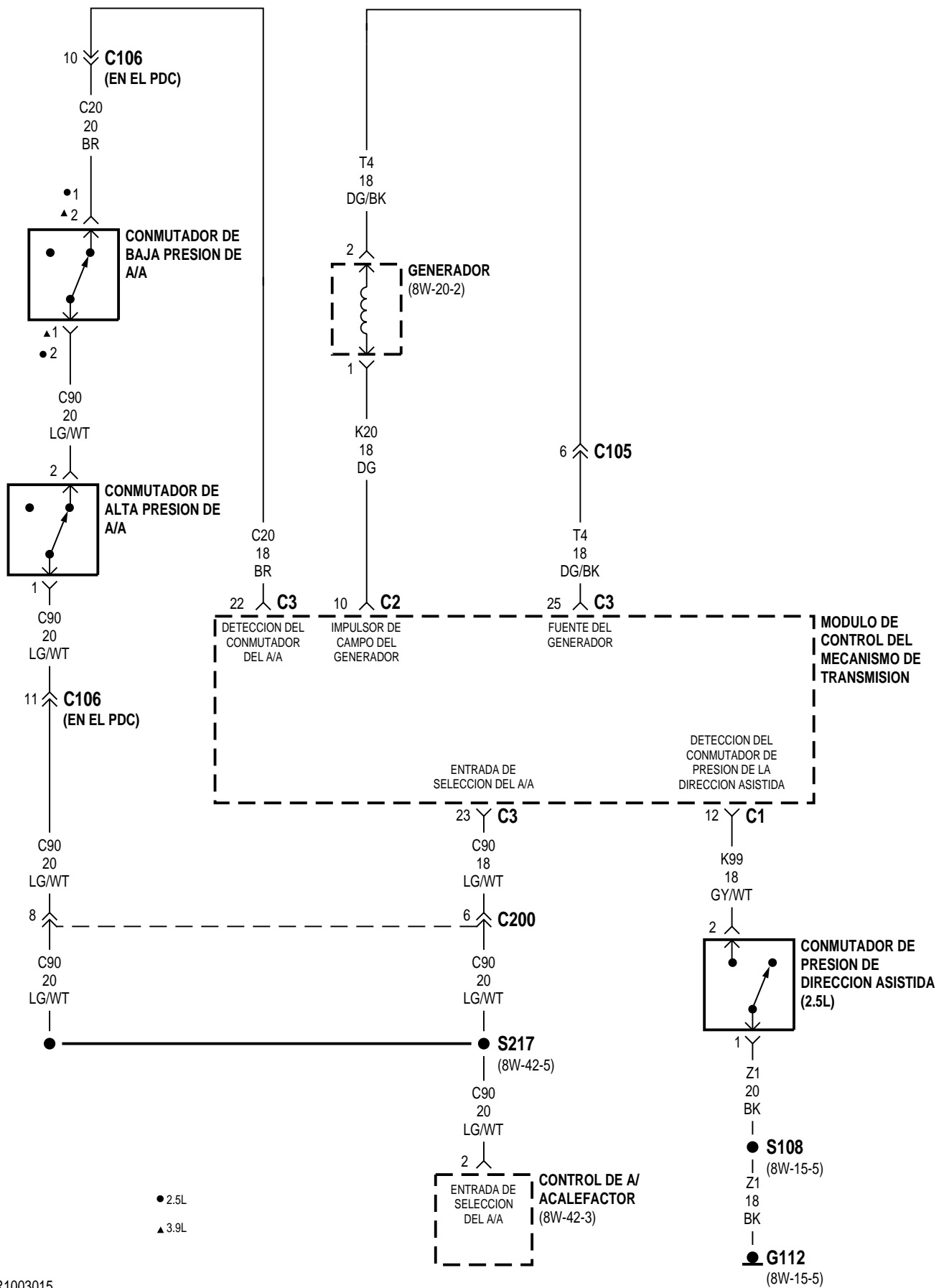

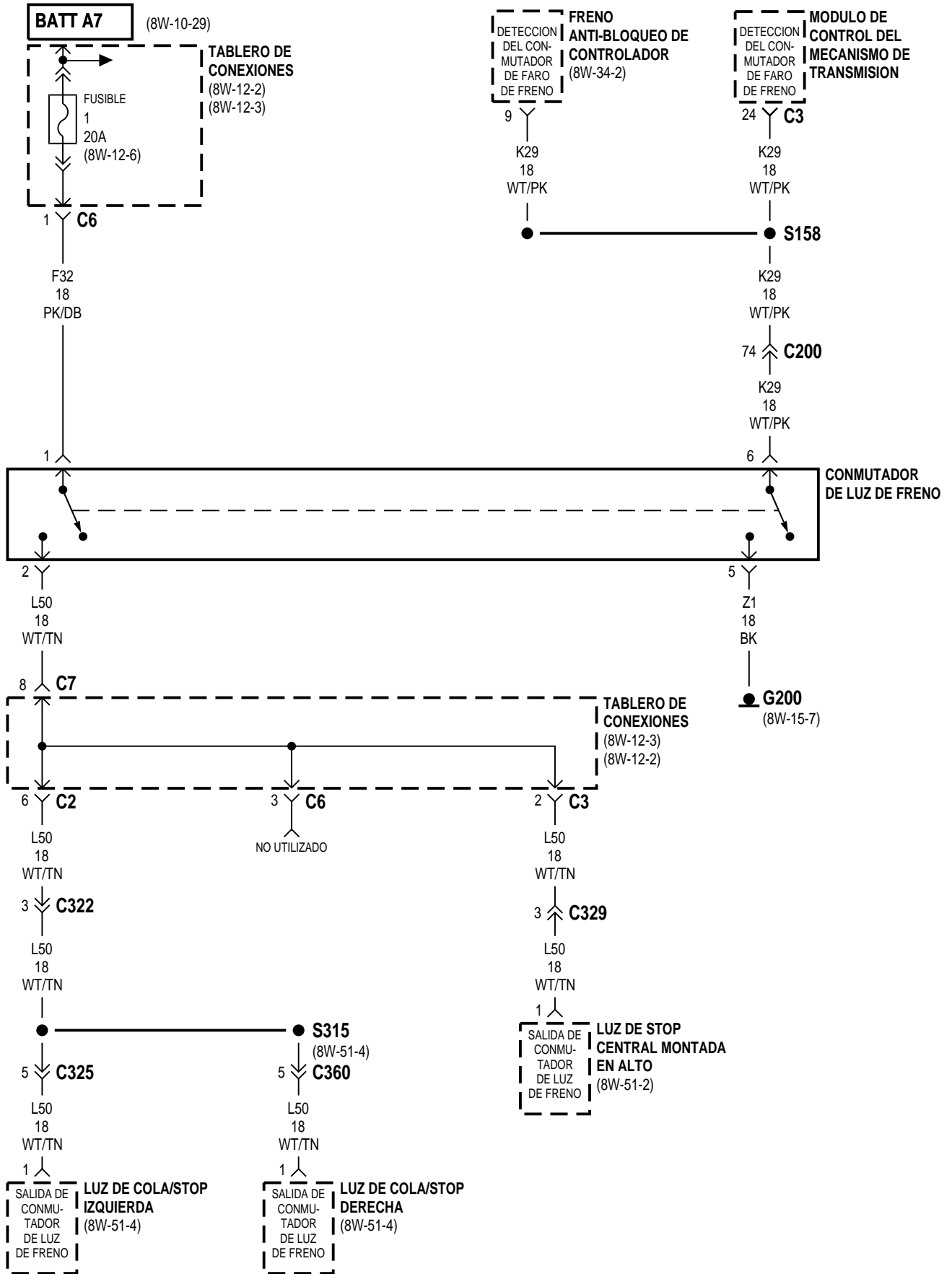

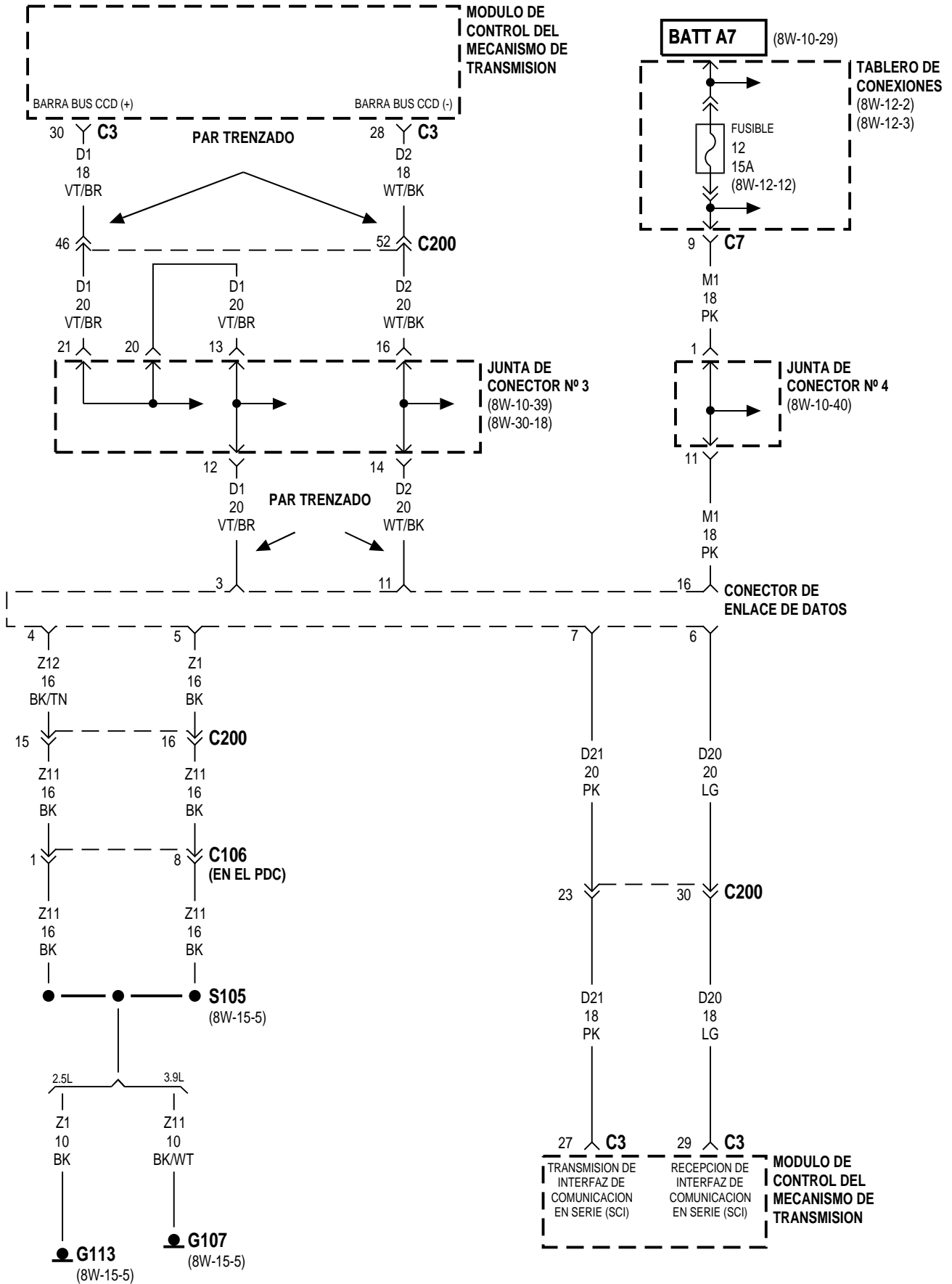

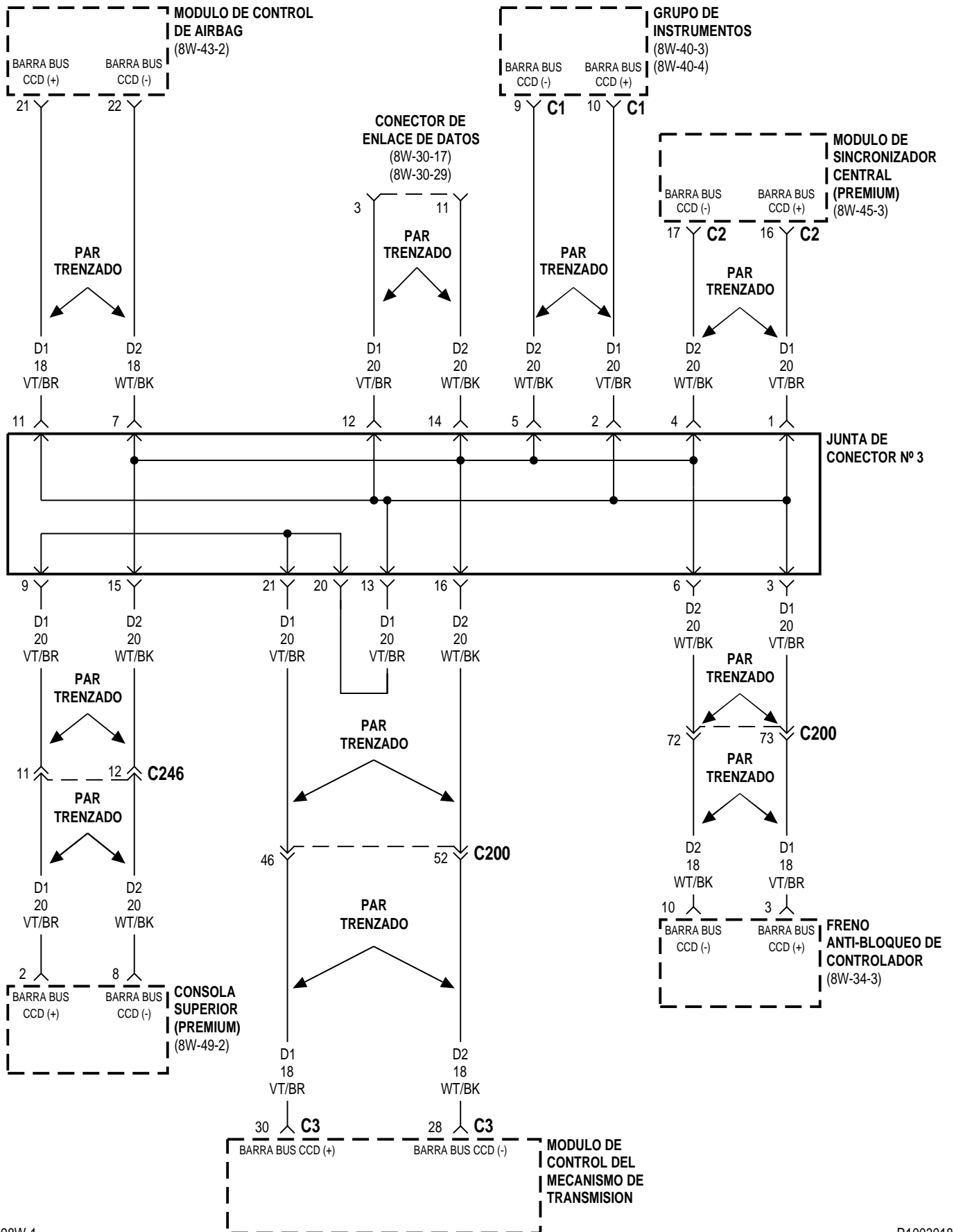

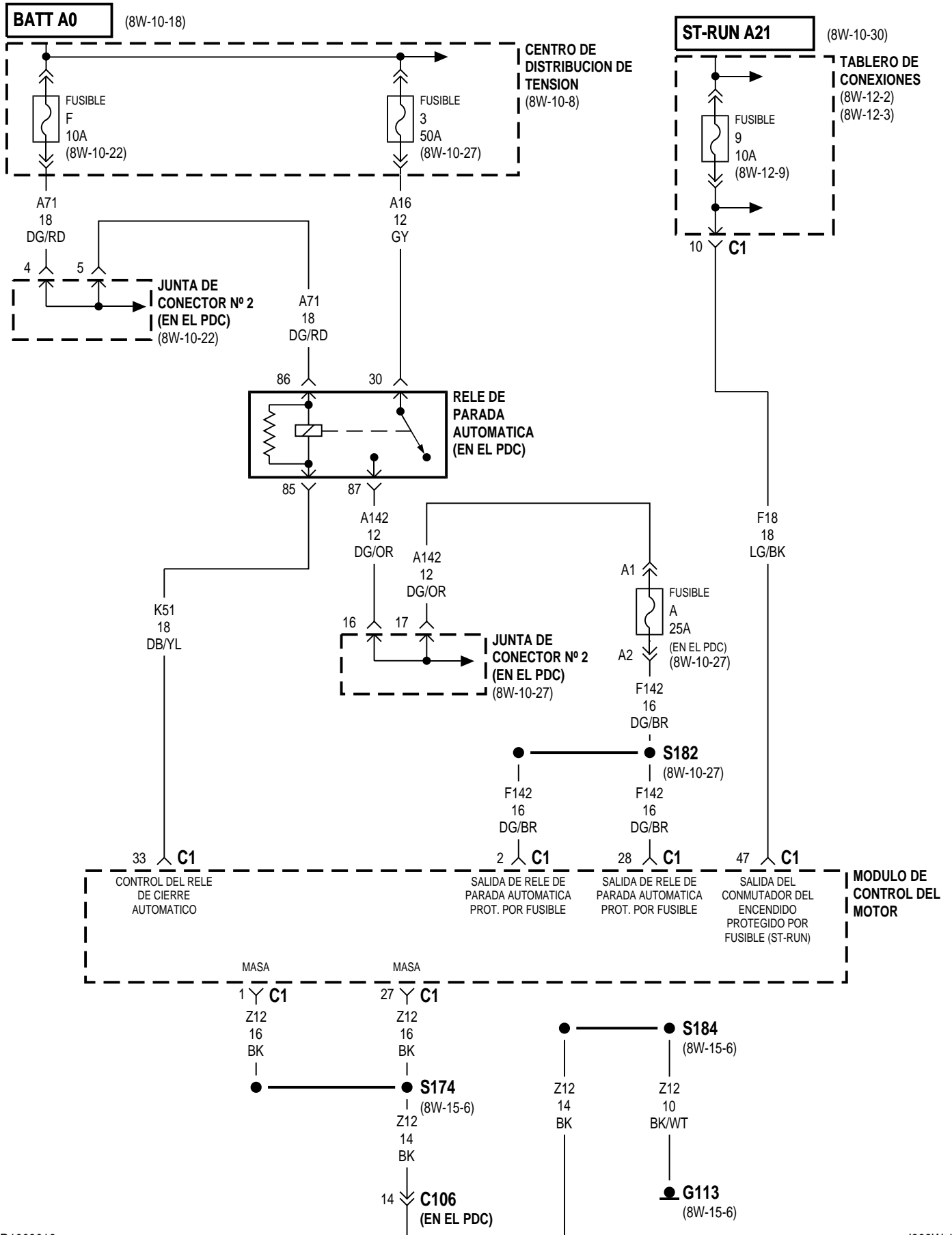

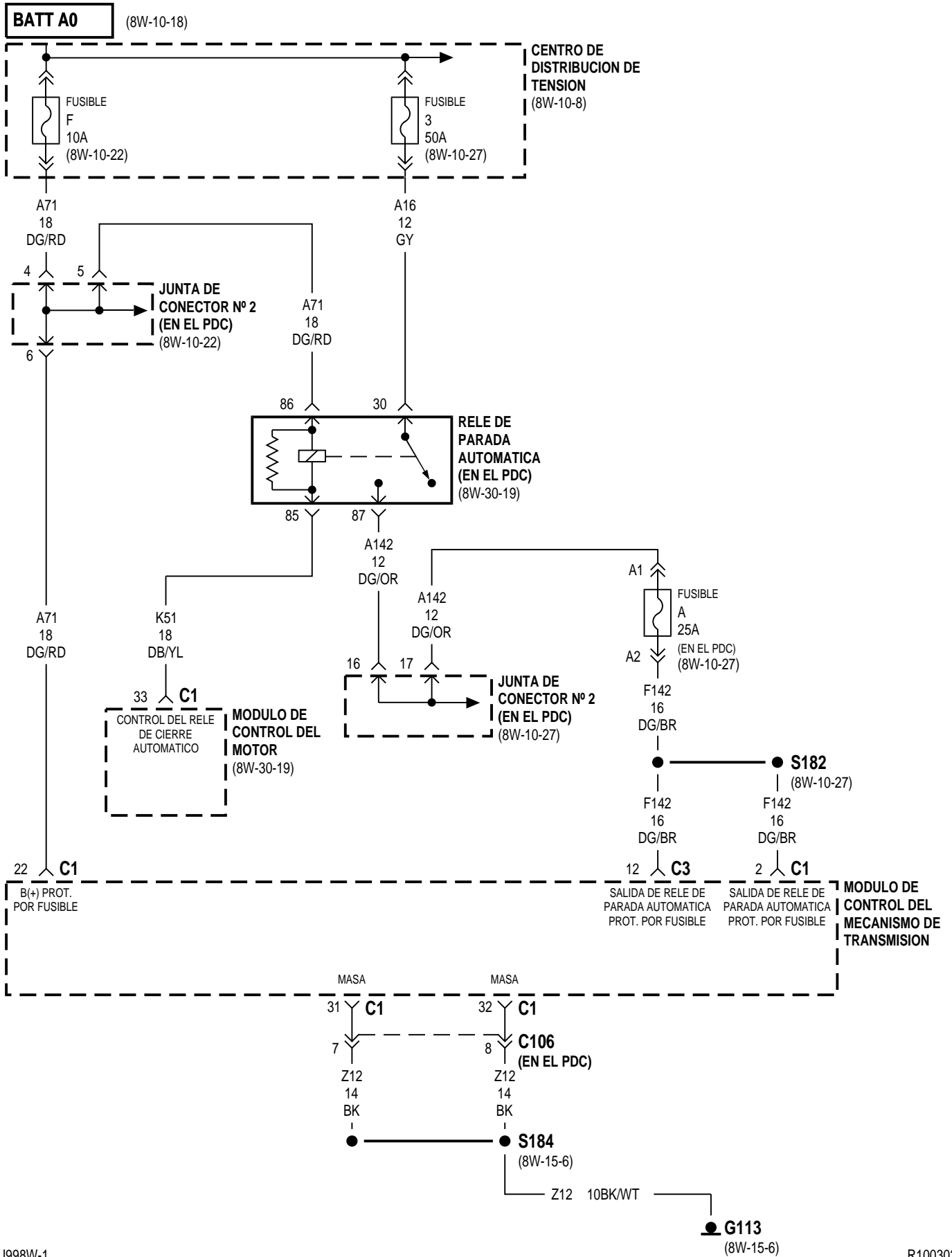

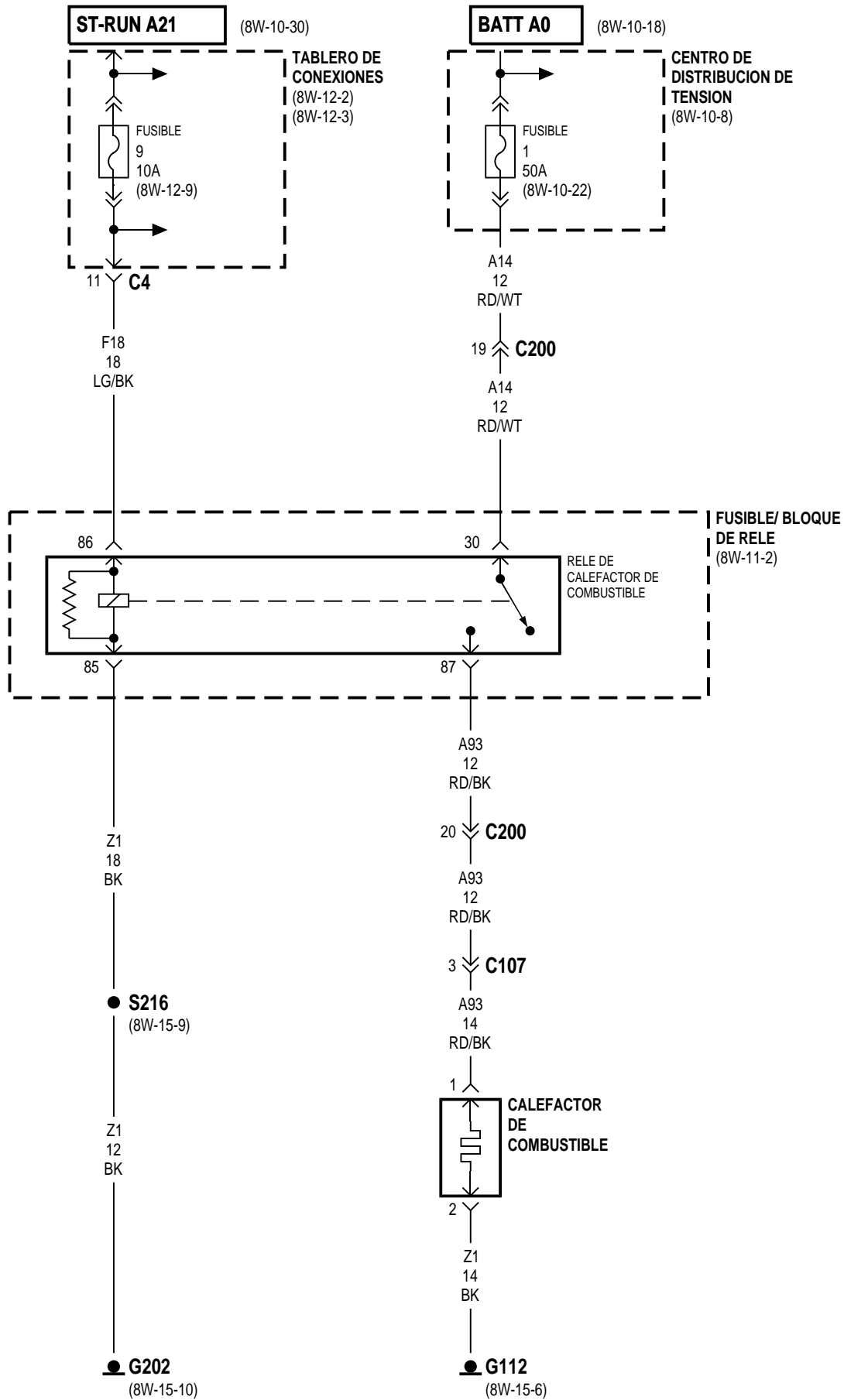

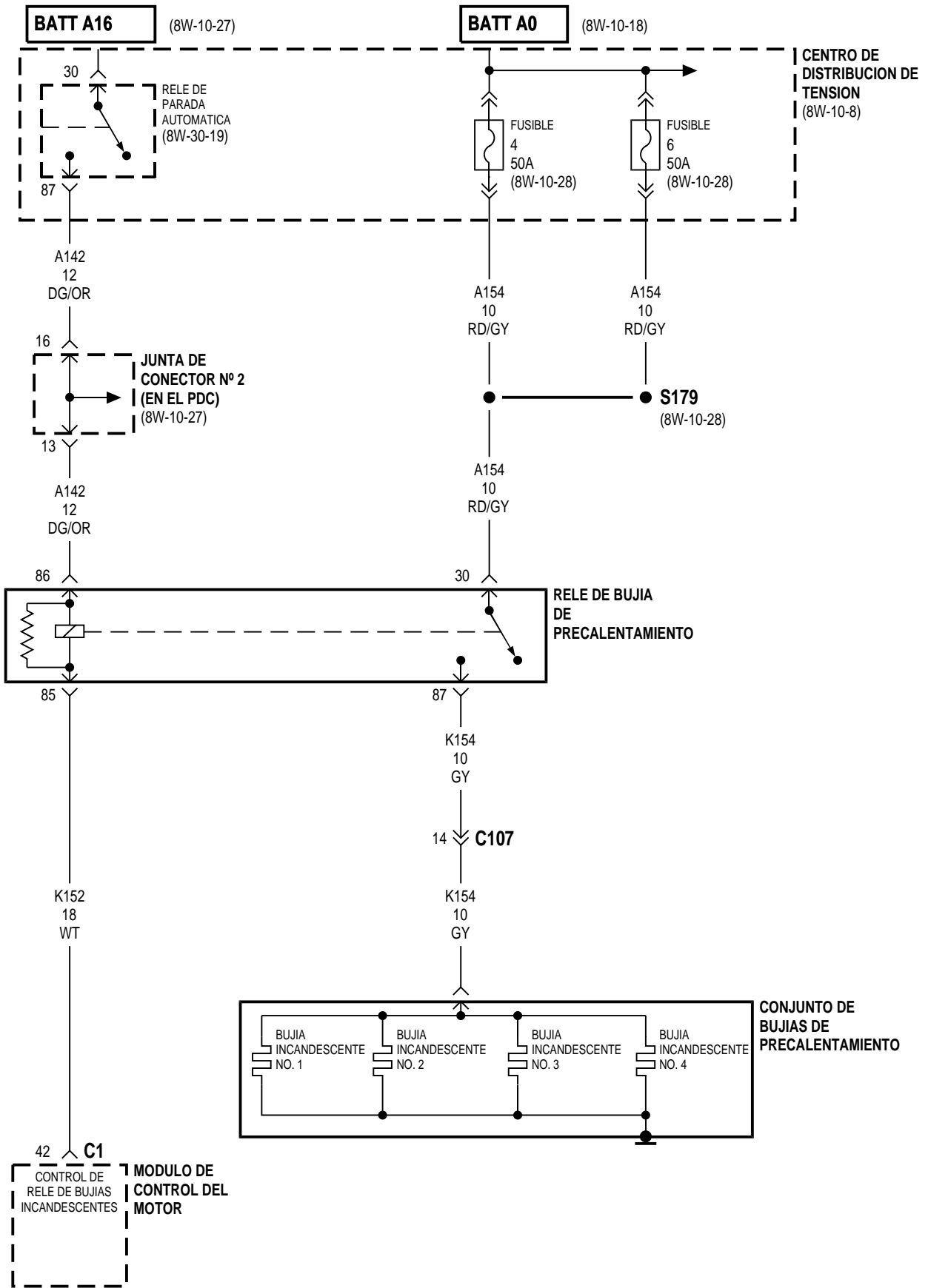



**SENSOR DE POSICION DE PEDAL DEL ACELERADOR**

**SENSOR DE MOVIMIENTO DE AGUJA**

**MODULO DE CONTROL DEL MOTOR**

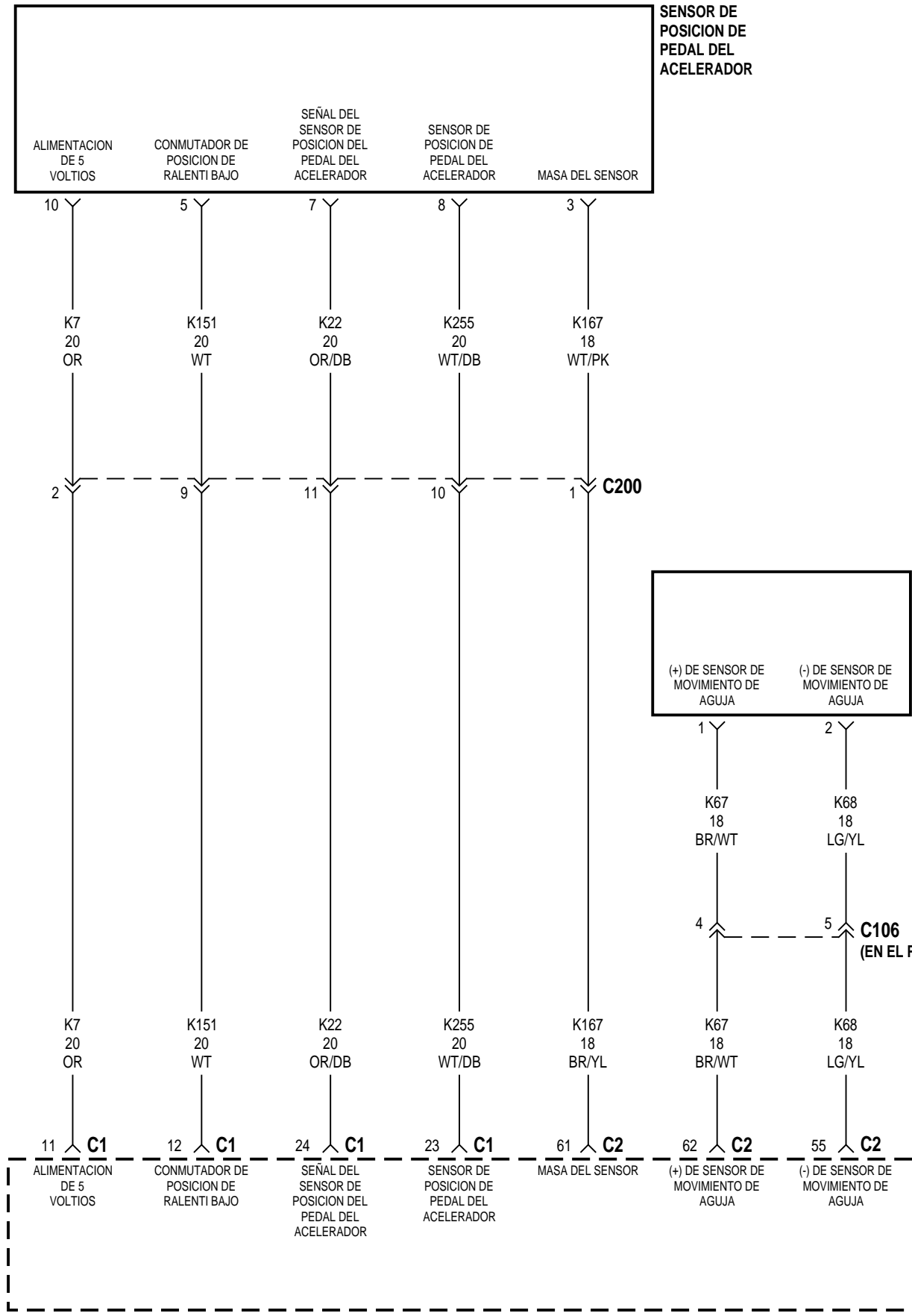

R1 **8W-30 SISTEMA DE COMBUSTIBLE/ENCENDIDO** 8W - 30 - 25 **DIESEL**

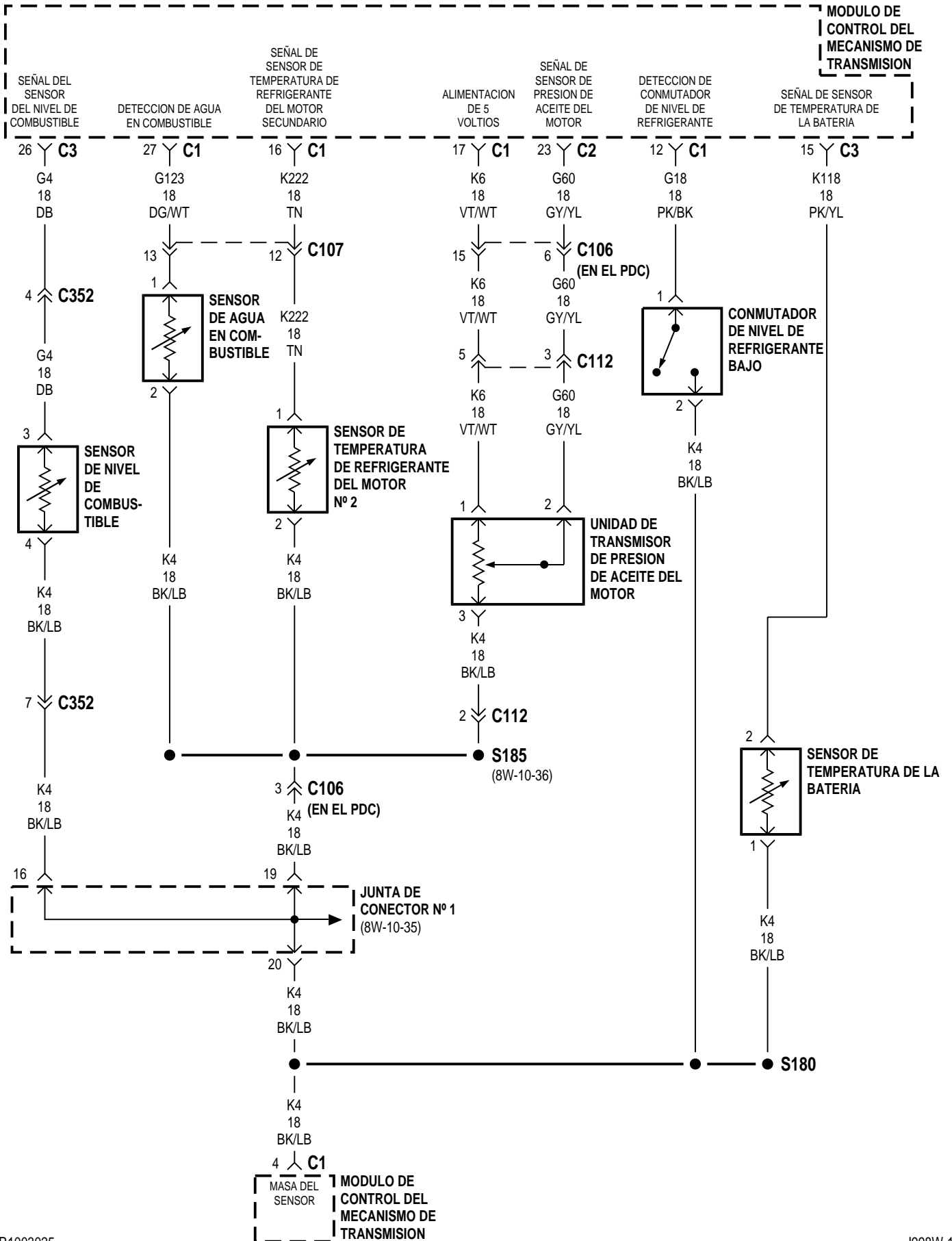

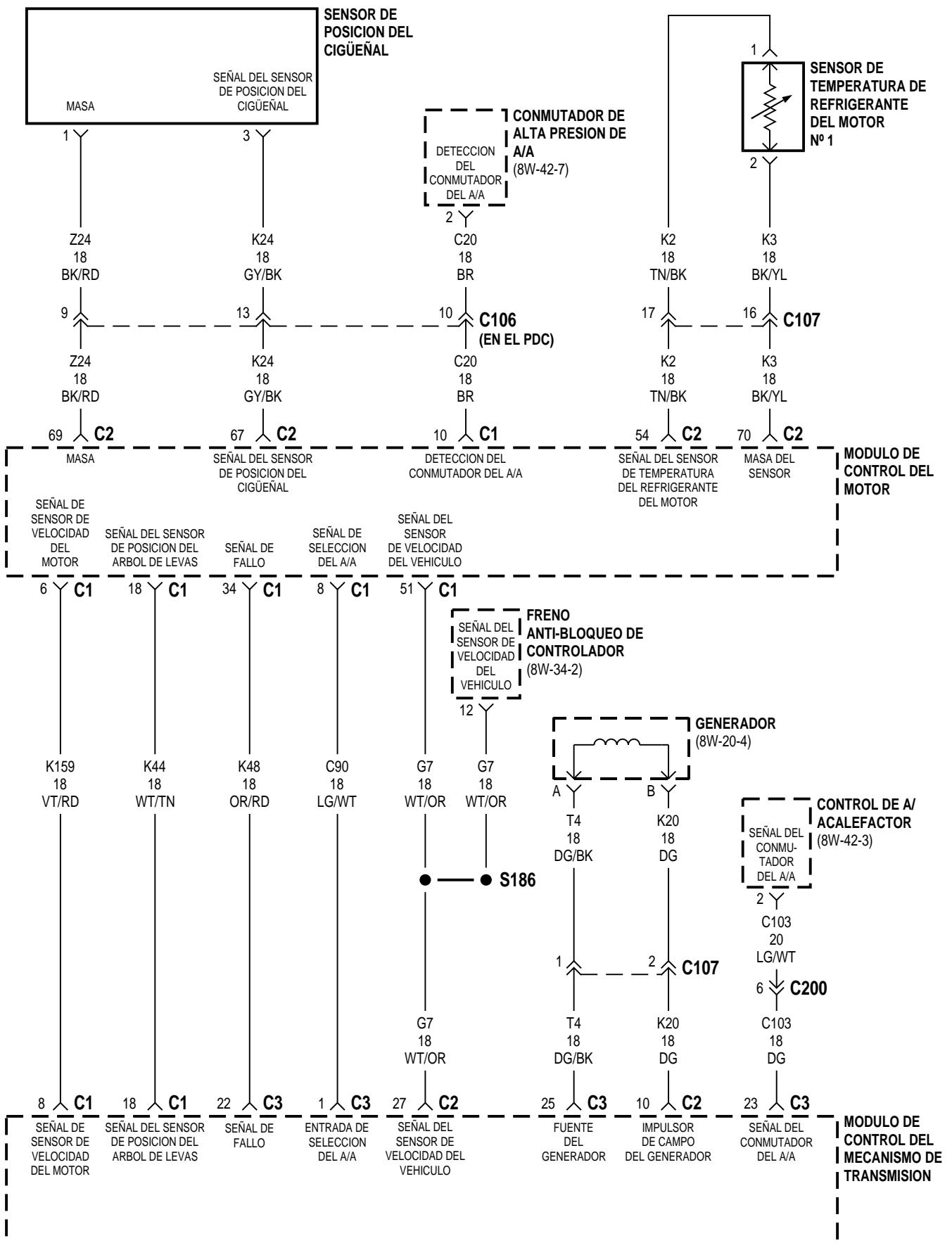

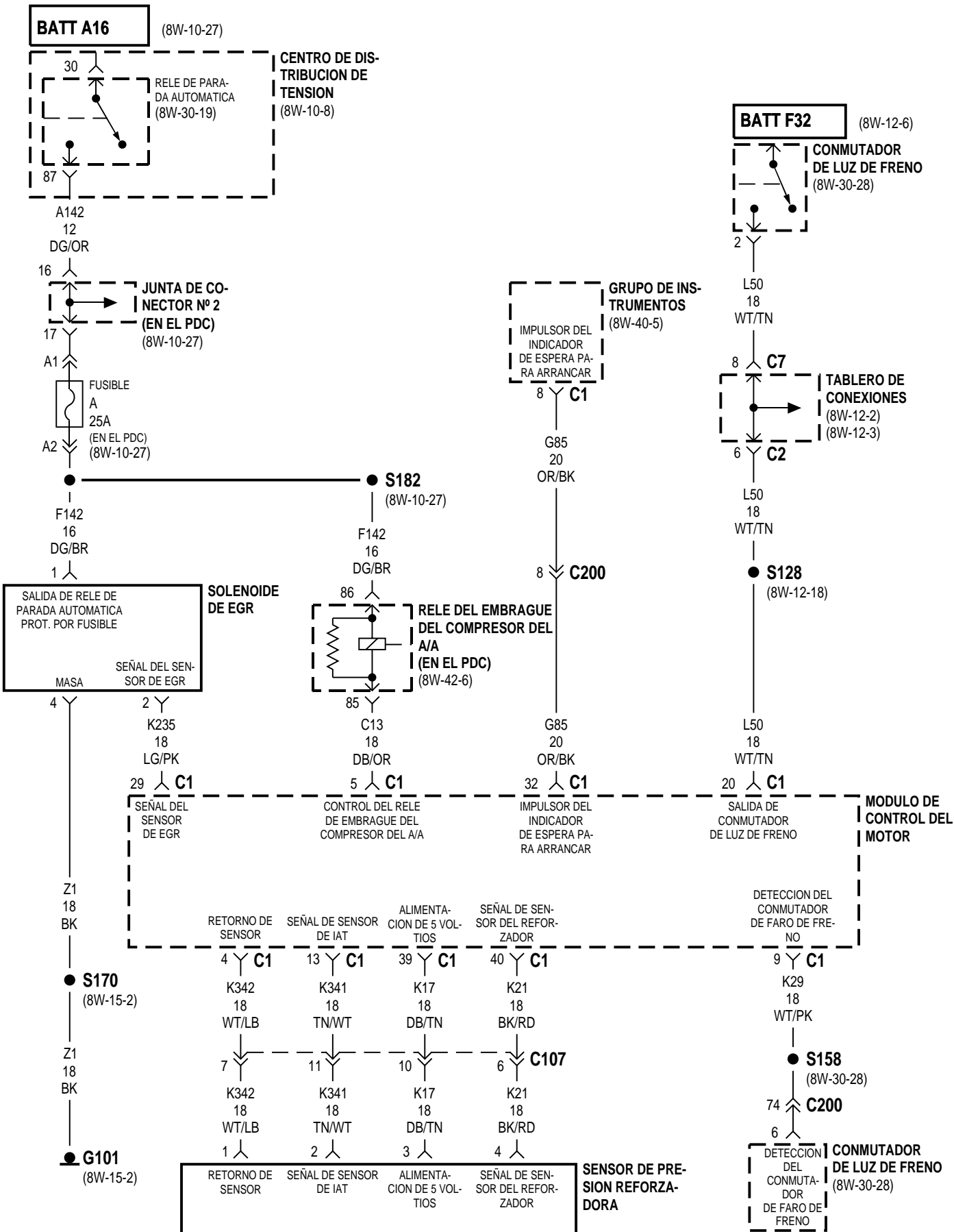

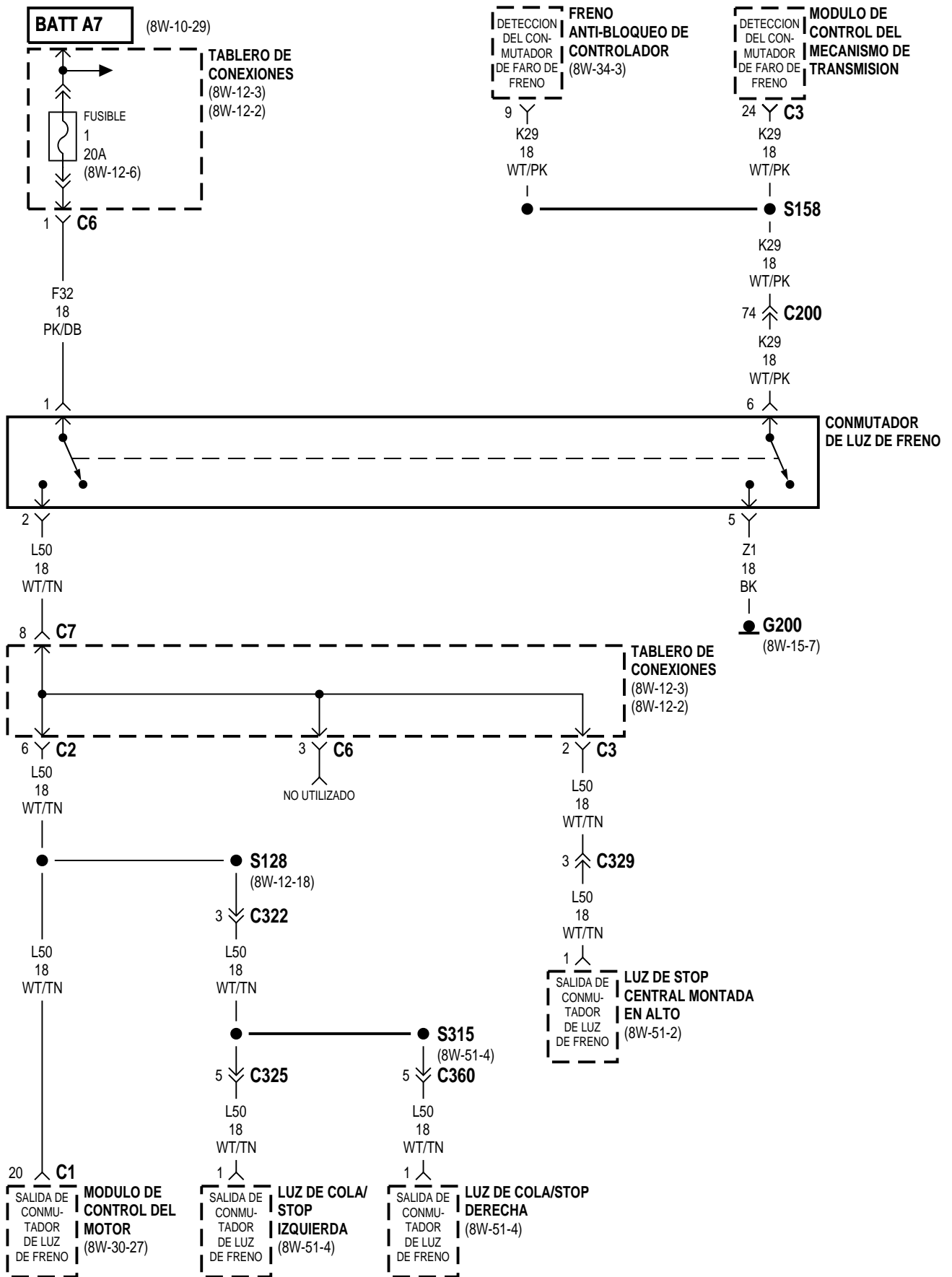

**DIESEL**

